



COMPANY PROFILE

NEOFLAM[®]

Bringing kitchens to life

Distributor of brand name housewares since 1990

The company was founded in 1990 in Korea as an importer and distributor of housewares from the US and Europe, including Weber grills, Igloo coolers, and kitchenware from ARC and Simax.

SIMAX



Luminarc

INTEX



Launched NEOFLAM branded products in 2006

Global recognition through innovative products

Neoflam began manufacturing in 2006 with the introduction of cutting boards with antimicrobial protection. We took the next step in 2008 by starting production of cast aluminum cookware with Ecolon ceramic coating. Neoflam has since been expanding into food storage, hydration, cutlery and bamboo products.



NEOFLAM's annual sales revenue

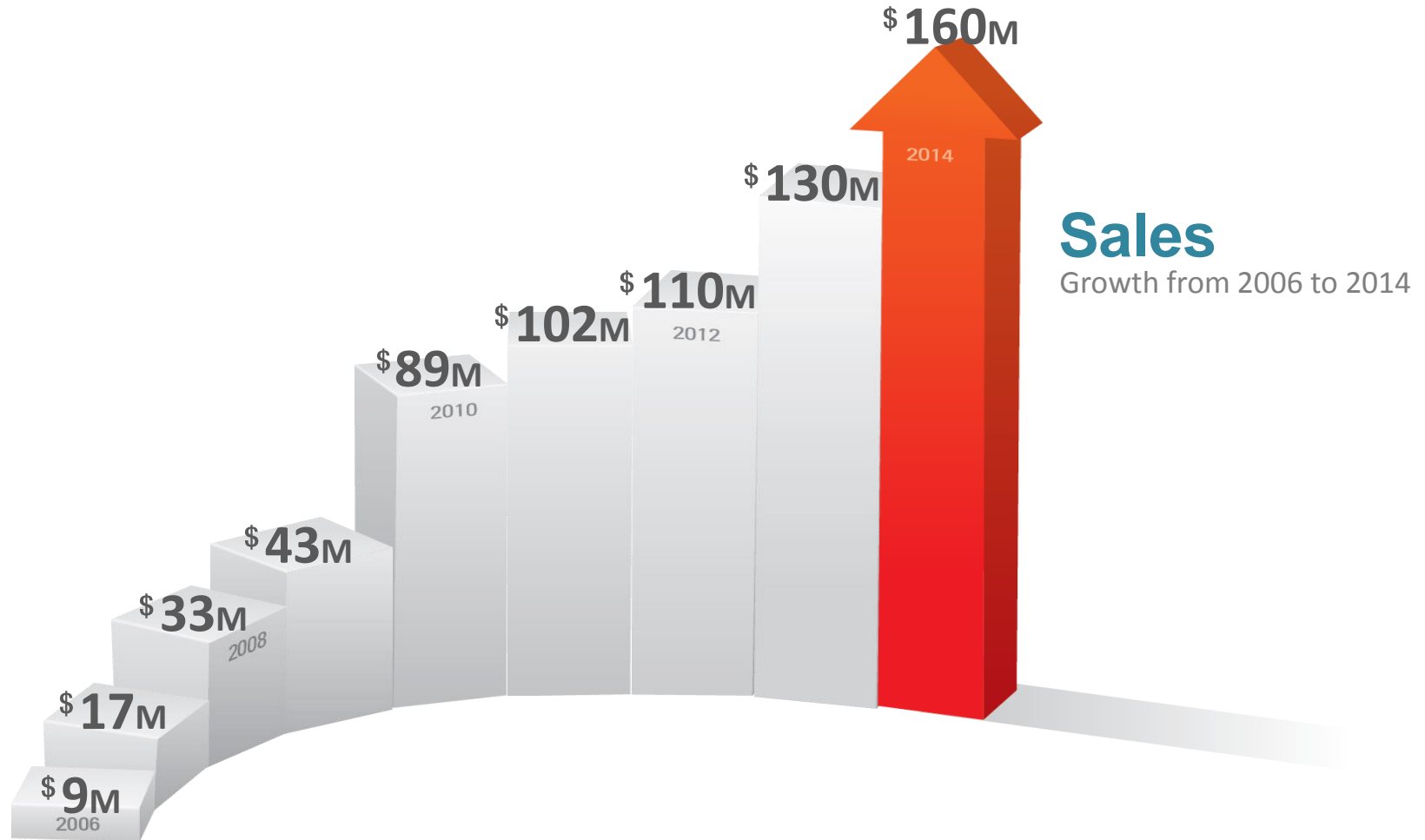

NEOFLAM's global coverage

Headquarters in Seoul, Korea
6 overseas sales companies



Key retail customers



NEOFLAM's production facilities

Neoflam is dedicated to providing innovative housewares that is beneficial for consumers and for the earth.



Ningbo

HAINING Fact
Ecolon Pan Cookware



Hwa-seong

KOREA

WONJU Factory
2014.07

Ecolon Pan Cookware



MUAN Factory

Ceramics Cookware



Production facilities

2nd largest ceramic coated cookware factory in the world



China Cookware factory

- 50,000m² (Land area)
- 15,000m² (Floor space)
- 2 Coating line



Korea Cookware factory

- 66,000m² (Land area)
- 30,000m² (Floor space)
- 4 Coating line



Cast aluminum cookware production capacity to reach 1.5M pcs/month in 2014

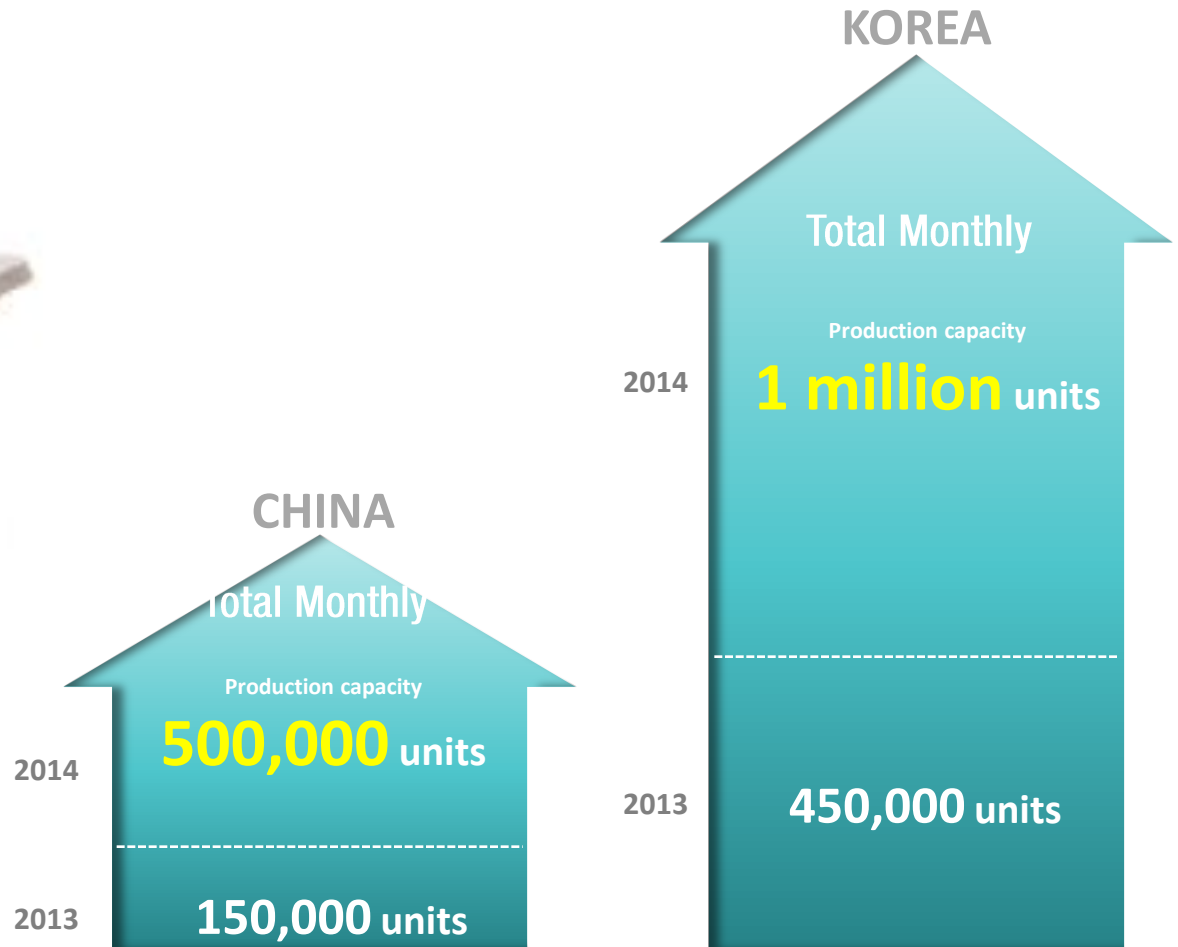

Production facilities

One of the largest cutting board factories in the world

Neoflam's joint venture factory has developed into one of the biggest cutting board factories in the world. The company has achieved ISO9001 and QS management policy,

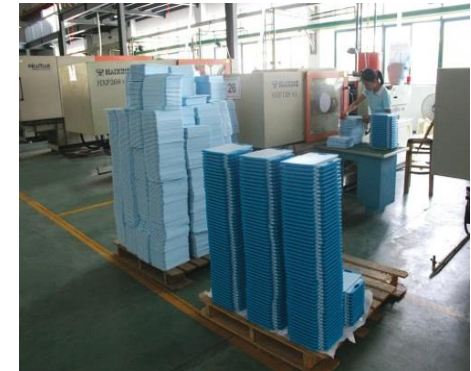

NEOFLAM's plastic cutting board has the largest market share in the world.

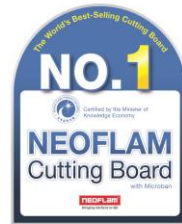

Production facilities

Food storage supplier with state of the art facilities

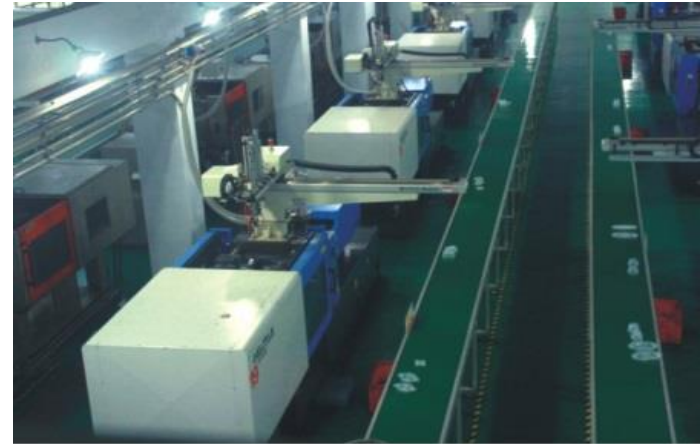

Production facilities

World Class Bamboo factory

Our bamboo factory has a production capacity of 200,000 pcs per month and can manufacture a diverse range of bamboo products from cutting boards, kitchen tools to sunglasses.

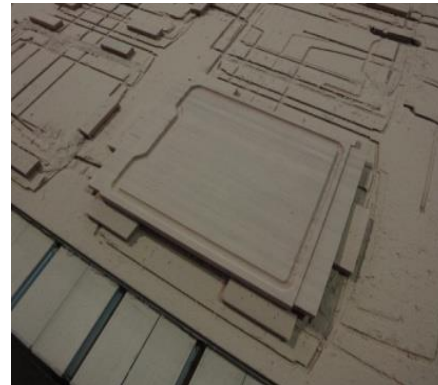

Ecolon coating technology



Ecolon is Neoflam's proprietary ceramic nonstick coating technology. Dedicated to consumer & environmental health, Neoflam has created Ecolon from the Earth's natural, sustainable minerals. All Ecolon Cookware lines feature the following benefits:

- Does not emit harmful substances such as PFOA, cadmium or lead.
- Highly scratch-resistant and durable.
- Powerful nonstick performance allows for cooking with reduced oil.
- Interior & exterior ceramic coating makes cleaning a breeze.



Award-winning designs

Neoflam is setting trends in housewares design by winning several world recognized design awards

2012



Eela



Aeni



Danby

2013



Aveco



DESIGN PLUS

Aveco

2014



Retro



Mystic Valley



Odense



The Brand of the Year
for the fourth consecutive year
2010-2013



The World's Best-Selling
Cutting Board & Cookware
2012-2013

Neoflam's patented products

Detachable handle technology

Patented System for attaching and releasing the handle



Detachable handle technology

Patented System for attaching and releasing the handle

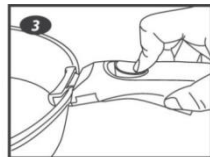

Steam regulating technology

Patented system for steam regulation on the glass lid

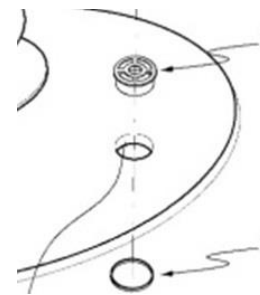

Technology for affixing handle directly to cast body

Patented system for attaching handle

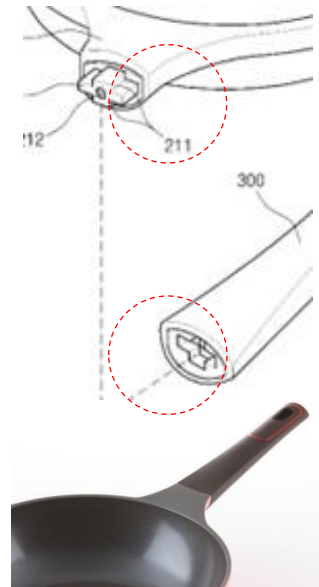

Neoflam's patented products

TPE-to-Bamboo technology



Permanent Seamless Edges

Neoflam's patented TPE-to-bamboo technology.

Neoflam has developed a method to attach TPE through over-molding to bamboo by developing a food-safe gluing agent that creates a permanent, seamless seal during the over-molding process.

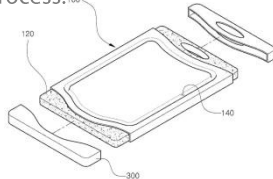

Twist-Lock technology (Food storage)

Patented lid-lock mechanism



Perfect Seal Dry food storage



Twist-Lock technology (Hydration)

Patented lid-lock mechanism



Hydration bottle

Detachable technology (Knife block)

Patented knife block structure

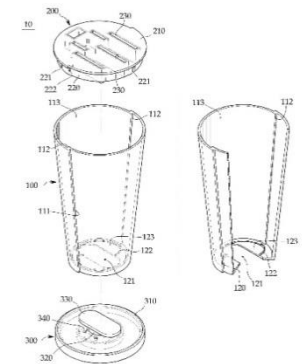

Neoflam's R&D and QA capabilities

In-house R&D

Neoflam has always focused on creativity and functionality. As a result, we have been awarded many prestigious design awards from around the world.

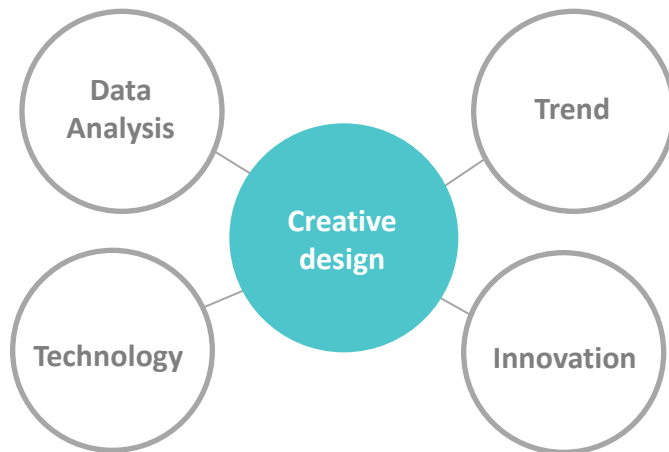

Possess over **20** professionals including **15** designers

QA Team



Possess over **20** QA professionals in Korea and China

NEOFLAM marketing activities

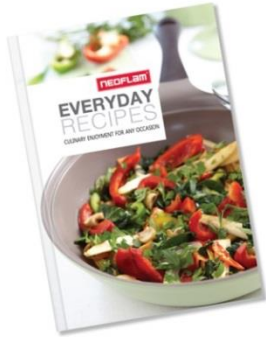

Cookbook



Department stores



P.O.P stand



Outdoor advertising

Celebrity chef cooking show



NEOFLAM exhibitions



Ambiente Show



Chicago Show



Brazil House & Gift Fair



Canton Fair

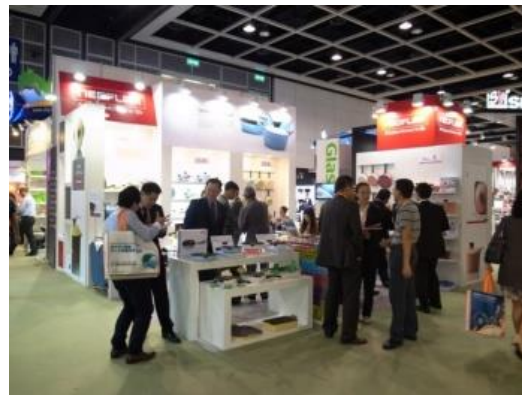

Hong Kong Show



Trade Show in Istanbul